

APPROVED	CHECKED	DESIGNED	DRAWING	SCALE	DRAWING NO.	WEIGHT
						32kg

ミートスライサ  
MEAT SLICER

HS-17

SPECIFICATION		NO	ARTICLES	名称	MATERIAL	QUAN	REMARKS
WATTAGE	150W	1	BODY	本体	AL	1	ALUMITE FINISH
VOLTAGE	100/220VAC	2	CUTTER	丸刃	SUG	1	
PHASE	1φ	3	GUIDE OF HAM BED	ガイド	AL	1	ALUMITE FINISH
CYCLE	60Hz	4	CUTTER COVER	丸刃カバー	AL	1	ALUMITE FINISH
		5	AUTO. CHANGE LEVER	自動切換レバー	SS400	1	Cr-PLATED
CAPACITY	2800P. C. S/h	6	MAN. HANDLE	手動ハンドル	SS400	1	Cr-PLATED
		7	REGULATOR	厚み調整ダイヤル	SS400	1	KNOB: BAKELITE
		8	HAM WEIGHT	ハム押え	SS400	1	Cr-PLATED
		9	HAM WEIGHT	ハム押え	SS400	1	Cr-PLATED
		10	SWITCH	電源スイッチ		1	
		11	CORD	コード		1.5m	
		12	LEG	取り付け脚	SUS430	2	

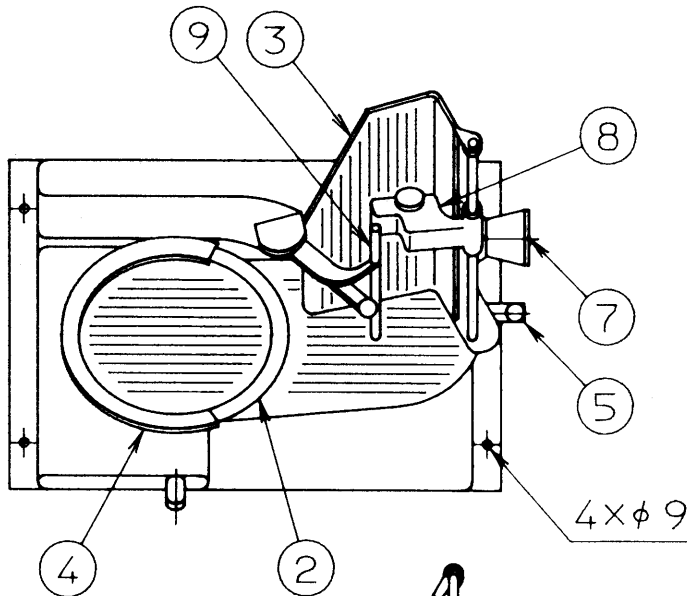

WITH PLUG: JISF8832-1MB  
プラグ付き: ~~JISF8831-UB~~

