

SPECIFICATION	
HOT PLATE	5.0KW × 3
OVEN	5.0KW
TOTAL WATTAGE	20.0KW
VOLTAGE	440VAC
PHASE	3 φ
CYCLE	60Hz
BODY	POLISHED
OVEN SIZE	515W × 470D × 360H

No.	ARTICLES	名称	MATERIAL	Q'TY	REMARKS
1	BODY	本体	SUS430	1set	
2	TOP PLATE	頂板	SUS430	1set	
3	DRIP PAN	汁受け皿	SUS430	2	
4	HOT PLATE	ホットプレート		3	5000W
5	ROLLING BAR	ローリングバー	SUS430	1set	
6	OVEN	焼オープン	SUS430	1	
7	OVEN HEATER	オープンヒーター	SUS304	6	830W
8	INSULATION	断熱材	ROCKWOOL	1set	25t
9	OVEN EXHAUST	オープン排気口		1	
10	HAND RAIL	手摺	SUS304	1	20A
11	CABLE GLAND	ケーブルグランド	BC	1	25b
12	LEG	脚	SUS430	4	
13	FOOT PIECE	取付脚		4	
14					

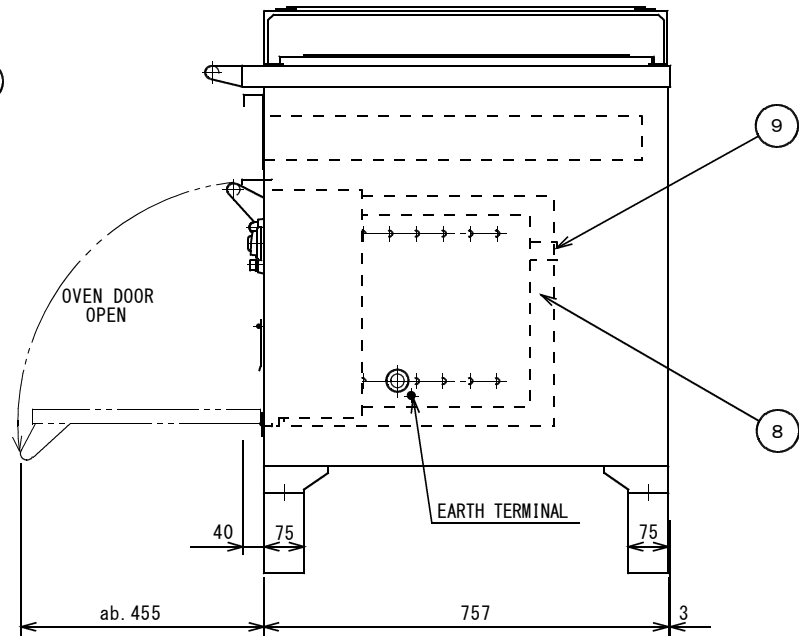
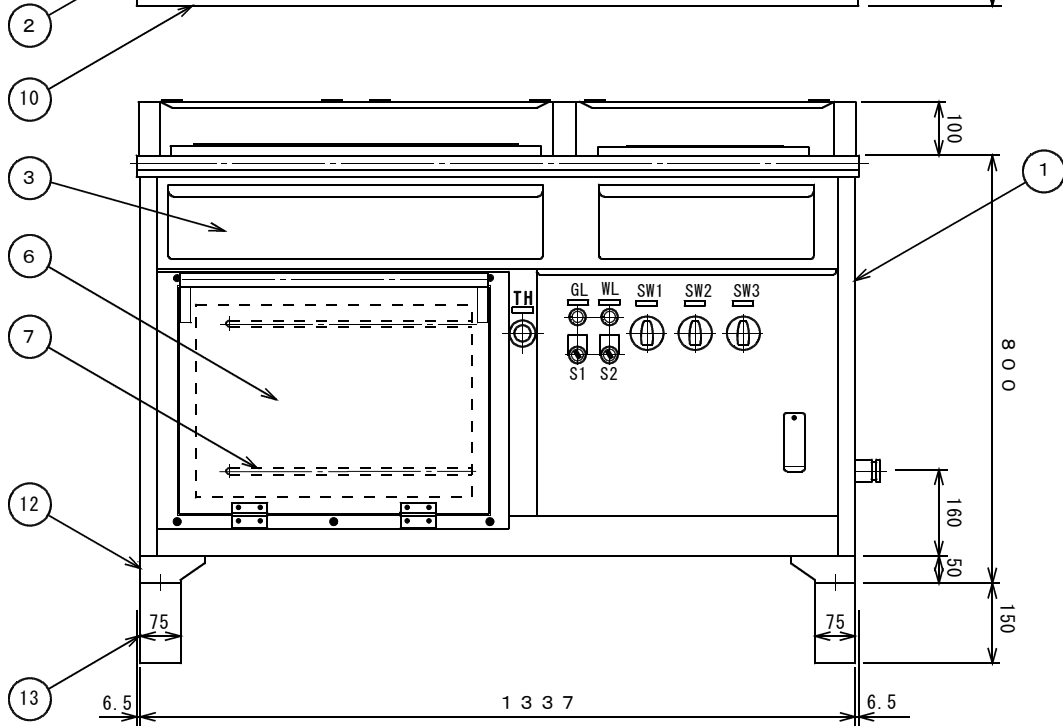

APPROVED BY	CHECKED BY	DESIGNED BY	DRAWN BY	SCALE	WEIGHT	ELECTRIC COOKING RANGE 電気レンジ
			K. Ashizawa 2009.12.08	1/10	ab. 200 Kg	
SANWA CHURI INDUSTRY CO., LTD.				DRAWING NO. G508251		ROH555-4