

No.	ARTICLES	名称	MATERIAL	Q'TY	REMARKS
1	BODY	本体	SUS430	1set	
2	TOP PLATE	頂板	SUS430	1set	
3	GRILL HEATER	魚焼きヒーター	SUS304	24	500W
4	DRIP PAN	汁受け皿	SUS430	3	
5	HOT PLATE	ホットプレート		2	4000W
6	ROLLING BAR	ローリングバー	SUS430	1set	
7	OVEN	焼オープン	SUS430	1	
8	OVEN HEATER	オープンヒーター	SUS304	6	830W
9	INSULATION	断熱材	ROCKWOOL	1set	25t
10	OVEN EXHAUST	オープン排気口		1	
11	HAND RAIL	手摺	SUS304	1	20A
12	CABLE GLAND	ケーブルグランド	BC	1	25c
13	LEG	脚	SUS430	5	
14	FOOT PIECE	取付脚		6	

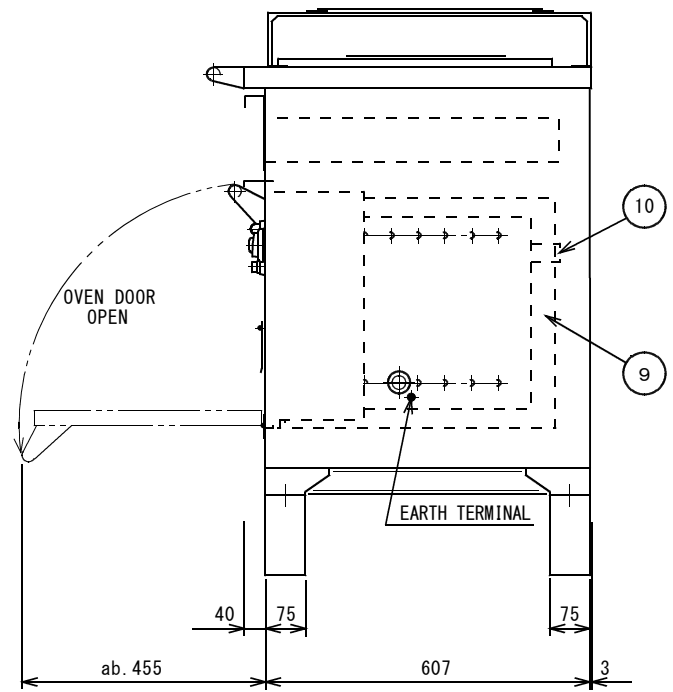
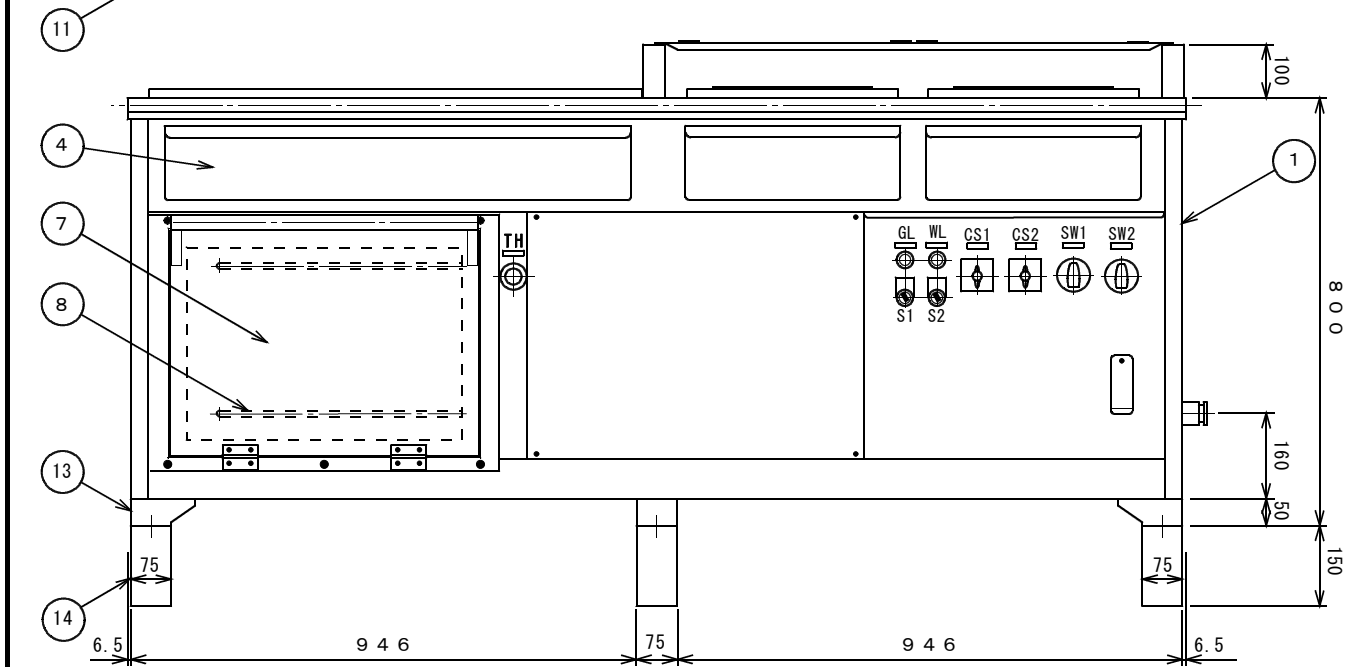

SPECIFICATION			
GRILL	6.0KW × 2	VOLTAGE	440VAC
HOT PLATE	4.0KW × 2	PHASE	3 φ
OVEN	5.0KW	CYCLE	60Hz
		BODY	POLISHED
TOTAL WATTAGE	25.0KW	OVEN SIZE	515W × 470D × 360H

APPROVED BY	CHECKED BY	DESIGNED BY	DRAWN BY	SCALE	WEIGHT
			K. Ashizawa 2009.12.08	1/10	ab. 270 Kg
SANWA CHŪRI INDUSTRY CO., LTD.				DRAWING NO. G501451	

ELECTRIC COOKING RANGE	
電気レンジ	
ROH44GC-4	